

## 典型性能 Features

- ◆ 50-200 瓦功率输出 (50-200 Watts of Output Power)
- ◆ 超宽电压输入 (4:1 Wide Range Input)
- ◆ 长期短路保护, 自恢复 (Short Circuit Protection, Automatic Recovery)
- ◆ 小型化封装 (Small Package)

## 电气特性 Electrical Specifications

输入特性 Input	Min	Type	Max	Notes
输入电压范围 Input Voltage Range	9V	12V/24V	36V	DC
	18V	24V/48V	72V	
	18V	24V	36V	
	36V	48V	72V	
启动延时时间 Start-up Delay Time		10mS		
控制功能 ON/OFF Control	正逻辑	ON		CNT 悬空或接TTL高电平 CNT pin left open or CNT pin connected to TTL logic high
		OFF		CNT 与-Vin 相连 CNT pin is at a logic low
	负逻辑 尾缀 P	OFF		CNT 悬空或接TTL高电平 CNT pin left open or CNT pin connected to TTL logic high
		ON		CNT 与-Vin 相连 CNT pin is at a logic low
逻辑低 Logic Low			1.0 V	
输入欠压保护 Input. Under-voltage Lockout	6V		9V	9-36V 输入
	13V		18V	18-36V/18-72V 输入
	30V		35V	36-72V输入
输出特性 Output	Min	Type	Max	Notes
输出电压精度 Set point Accuracy		±1%	±3%	一路
负载效应 Load Regulation		±0.5%	±0.5%	一路
源效应 Line Regulation		±0.2%	±0.2%	一路
输出电压调节 TRIM Range			±10%	
动态响应 Dynamic Response			4%Vo Pk deviation 400μS settling time	50~75% load 50~25% load
温度系数 Temperature Regulation		±0.2%/°C		
输出过流保护 Current Limit Threshold	110%		160%	
过温度保护 Over Temperature Protection	105°C	115°C	125°C	
输出过压保护 Over-voltage Protection	110%		140%	
短路保护 Short-Circuit Protection	长期短路自恢复 Continuous, Automatic Recovery			
综合特性 General	Min	Type	Max	Notes

隔离电压 Isolation Voltage		1500VDC			Input to Output
		1000VDC			Input to Case
		500VDC			Output to Case
开关频率 Switching Frequency			300KHz		
平均故障间隔时间 MTBF			2×10 <sup>6</sup> Hrs		Mil HDBK 217F Tc=25℃
工作壳温 Case Temperature	工业级	-40℃		+90℃	
	AD、AG 级	-40℃		+100℃	
	AHII 级	-55℃		+105℃	
储存温度 Storage Temperature		-55℃		+125℃	
相对湿度 Relative Humidity		10%		90%	
管脚焊接温度 Pin Solder Temperature				250℃	Wave Solder <10S
手工焊接时间 Hand Soldering Time				5S	Iron Temperature 425℃
传导 Conducted Emission	GB9254/CISPR22/EN55022 Class B (推荐电路见图)				
静电放电 Electrostatic Discharge	GB17626/EN61000-4-2 Contact ±4KV				
浪涌抗扰度 Surge Immunity	GB17626/EN61000-4-5 ±2KV (推荐电路见图) perf. Criteria B				
脉冲群抗扰度 Electrical Fast Transient	GB17626/EN61000-4-4 ±2KV (推荐电路见图) perf. Criteria B				

型号 Models	输入电压范围 Input Voltage Range	输出电压 (Vdc) Output Voltage	输出电流 (A) Output current	纹波噪声(mv) Ripple and noise	典型效率 Efficiency	容性负载(μF) Max.Capacitor Load
WDE50-24S3V3W	9-36V	3.3	10	100	90%	10000
WDE50-24S5W	9-36V	5.0	10	100	91%	10000
WDE50-24S12W	9-36V	12	4.17	150	91%	2200
WDE50-24S15W	9-36V	15	3.33	150	91%	2200
WDE50-24S24W	9-36V	24	2.08	150	90%	1000
WDE50-24S28W	9-36V	28	1.79	150	90%	1000
WDE50-24S48W	9-36V	48	1.04	400	88%	470
WDE50-48S3V3W	18-72V	3.3	10	100	90%	10000
WDE50-48S5W	18-72V	5.0	10	100	91%	10000
WDE50-48S12W	18-72V	12	4.17	150	91%	2200
WDE50-48S15W	18-72V	15	3.33	150	91%	2200
WDE50-48S24W	18-72V	24	2.08	150	90%	1000
WDE50-48S48W	18-72V	48	1.04	400	89%	470
WDE100-24S3V3W	9-36V	3.3	20	100	90%	10000

WDE100-24S5W	9-36V	5.0	20	100	90%	10000
WDE100-24S12W	9-36V	12	8.33	150	90%	2200
WDE100-24S15W	9-36V	15	6.67	150	90%	2200
WDE100-24S24W	9-36V	24	4.17	150	90%	1000
WDE100-24S28W	9-36V	28	3.57	150	90%	1000
WDE100-24S48W	9-36V	48	2.08	400	88%	470
WDE100-24S55W	9-36V	55	1.81	500	88%	470
WDE100-48S3V3W	18-72V	3.3	20	100	91%	10000
WDE100-48S5W	18-72V	5.0	20	100	92%	10000
WDE100-48S12W	18-72V	12	8.33	150	92%	2200
WDE100-48S15W	18-72V	15	6.67	150	92%	2200
WDE100-48S24W	18-72V	24	4.17	150	90%	1000
WDE100-48S28W	18-72V	28	3.57	150	90%	1000
WDE100-48S48W	18-72V	28	2.08	400	89%	470
WDE150-24S12W	9-36V	12	12.5	150	92%	2200
WDE150-24S15W	9-36V	15	10	150	92%	2200
WDE150-24S24W	9-36V	24	6.25	150	90%	1000
WDE150-24S28W	9-36V	28	5.36	150	90%	1000
WDE150-48S12W	18-72V	12	12.5	150	92%	2200
WDE150-48S15W	18-72V	15	10	150	92%	2200
WDE150-48S24W	18-72V	24	6.25	150	90%	1000
WDE150-48S28W	18-72V	28	5.36	150	90%	1000
WDE200-24S12	18-36V	12	16.7	150	92%	2200
WDE200-24S15	18-36V	15	13.3	150	92%	2200
WDE200-24S24	18-36V	24	8.33	150	90%	1000
WDE200-24S28	18-36V	28	7.14	150	90%	1000
WDE200-48S12	36-72V	12	16.7	150	92%	2200
WDE200-48S15	36-72V	15	13.3	150	92%	2200
WDE200-48S24	36-72V	24	8.33	150	90%	1000
WDE200-48S28	36-72V	28	7.14	150	90%	1000

## 磁兼容应用 (EMC)

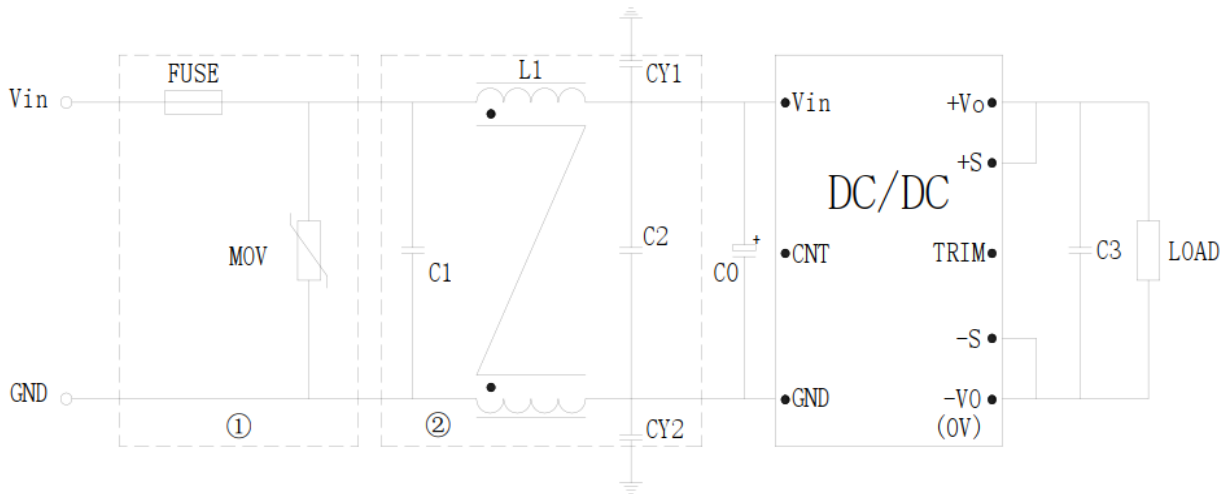

型号	VIN:12V	Vin: 24V	Vin: 48V
FUSE	根据具体电源模块型号电流选择		
MOV	14D101K	14D101K	14D101K
C0	220 $\mu$ F/25V	220 $\mu$ F/50V	100 $\mu$ F/100V
C1、C2	10 $\mu$ F/25V	4.7 $\mu$ F/50V	2.2 $\mu$ F/100V
C3	100 $\mu$ F		
LCM	2mH	5mH	
CY1、CY2	4.7nF Y2 安规电容		

**FUSE:**推荐采用慢熔型的产品，FUSE 电流选择要考虑高温降额和冲击电流的影响。

**MOV:**压敏电阻，MOV 可以和保险丝串联应用，防止 MOV 失效。也可以两只 MOV 串联，增加可靠性。

**C0 C3:**高频电解电容

**C1 C2:**高频独石电容或者薄膜电容。

**LCM:**共模电感。具体型号请咨询销售人员。

**CY1 CY2:**安规 Y2 电容

正逻辑 TRIM(尾缀加 S 产品):

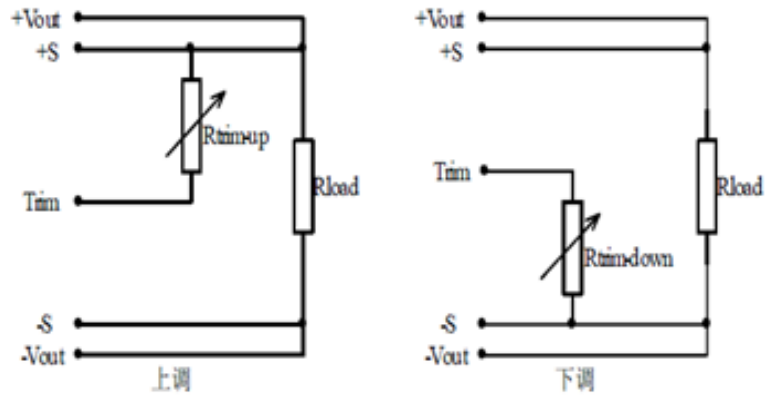

上调电阻计算公式  $R_{Trim-up} = \left( \frac{5.11 \times V_o(100(\%) + \Delta(\%))}{1.225 \times \Delta(\%)} - \frac{5.11 \times 100(\%)}{\Delta(\%)} - 10.22 \right) (K\Omega)$

下调电阻计算公式  $R_{Trim-down} = \left( \frac{5.11 \times 100(\%)}{\Delta(\%)} - 10.22 \right) (K\Omega)$

$V_o$ : 标称输出电压值;

$R_{Trim-up}$ 、 $R_{Trim-down}$ : 需外接的调节电阻;

$\Delta(\%)$ : 输出电压相对于标称输出电压的变化率。

例如模块输出上调10%时:

$$R_{Trim-up} = \left( \frac{5.11 \times 5 \times (100\% + 10\%)}{1.225 \times 10\%} - \frac{5.11 \times 100\%}{10\%} - 10.22 \right) (k\Omega)$$

$$= (229.43 - 51.1 - 10.22) (k\Omega) = 168.1(k\Omega)$$

## 机械图及管脚说明 (Unit: mm/ inch)

### 开放型 (不带散热器型号)

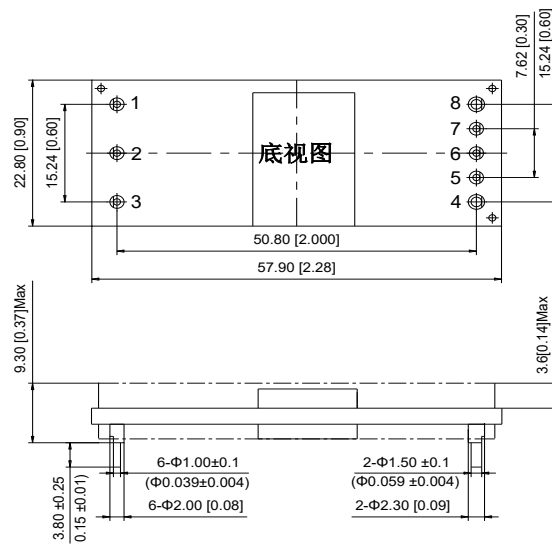

### 带散热器型 (尾缀 H)

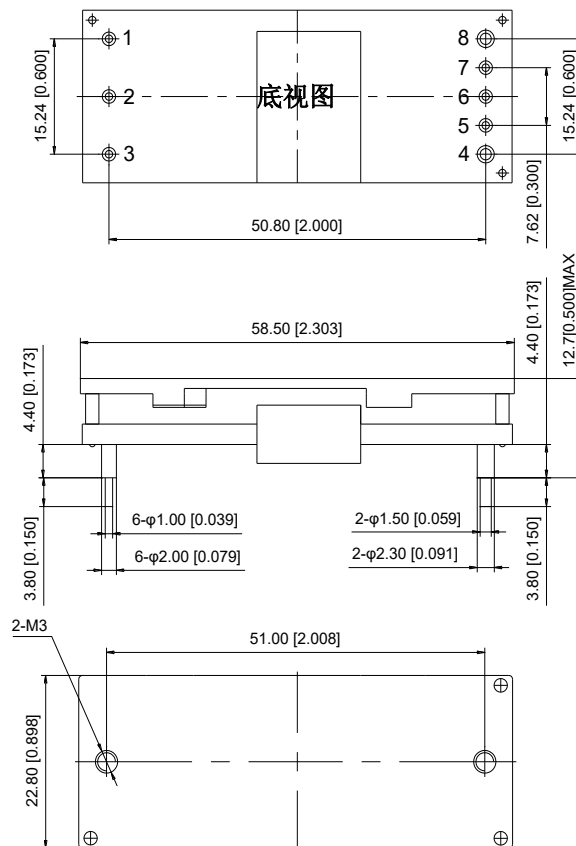

安装螺丝长度要求进入模块自带散热器的长度小于等于 2mm。

## 法兰安装（尾缀 F）

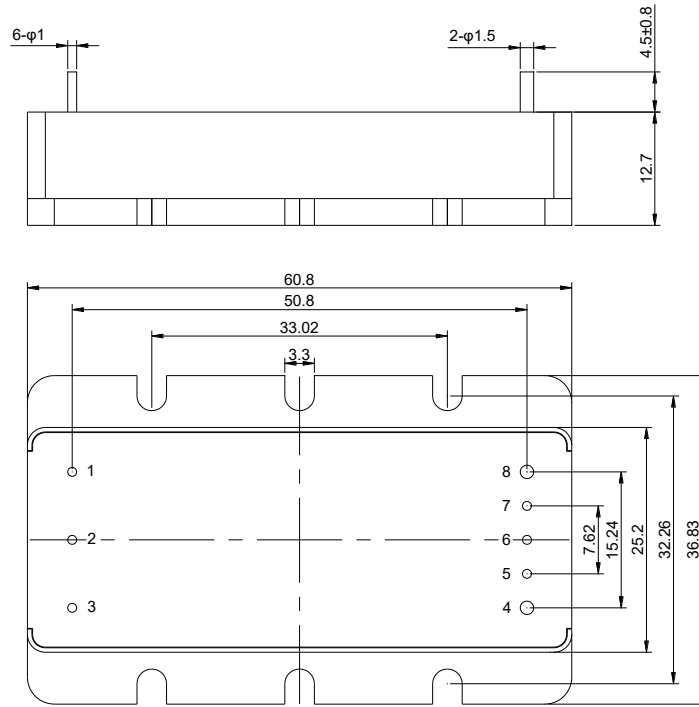

## 金属外壳型（尾缀 T）

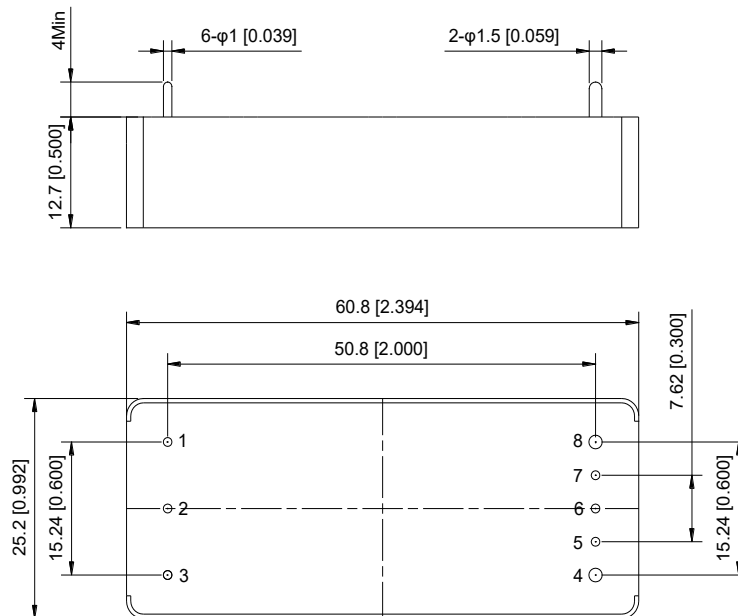

管脚	1	2	3	4	5	6	7	8
定义	-Vin	CNT	+Vin	+Vout	+S	Trim	-S	-Vout
说明	负输入	遥控端	正输入	正输出	正遥测	调整端	负遥测	负输出

注:安装定位尺寸公差按 GB/T1804-2000 F 级标准、外型尺寸公差按 GB/T1804-2000 C 级标准